

DEPARTMENT OF ELECTRICAL ENGINEERING

BASIC ELECTRICAL ENGINEERING (4 credit)

Course Code: 23UEEL1101

UNIT IV : INTRODUCTION TO AC MOTORS & DC MACHINES.

Introduction to Electric Machines

The operation of the three major classes of electric machines—DC, synchronous, and induction—first is described as intuitively as possible. The second part of the chapter is devoted to a discussion of the applications and selection criteria for the different classes of machines. The emphasis of this chapter is on explaining the properties of each type of machine, with its advantages and disadvantages with regard to other types; and on classifying these machines in terms of their performance characteristics and preferred field of application.

ROTATING ELECTRIC MACHINES

The range of sizes and power ratings and the different physical features of rotating machines are such that the task of explaining the operation of rotating machines in a single chapter may appear formidable at first. Some features of rotating machines, however, are common to all such devices. This introductory section is aimed at explaining the common properties of all rotating electric machines. We begin our discussion with reference to Figure 14.1, in which a hypothetical rotating machine is depicted in a cross-sectional view. In the figure, a box with a cross inscribed in it indicates current flowing into the page, while a dot represents current out of the plane of the page.

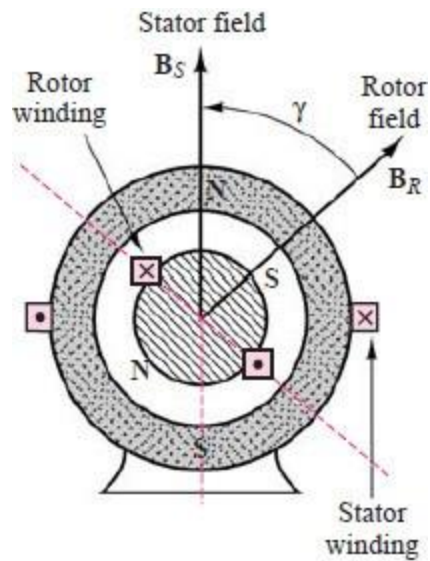

Figure 14.1 A rotating electric machine

In Figure 14.1, we identify a **stator**, of cylindrical shape, and a **rotor**, which, as the name indicates, rotates inside the stator, separated from the latter by means of an air gap. The rotor and stator each consist of a magnetic core, some electrical insulation, and the windings necessary to establish a magnetic flux (unless this is created by a permanent magnet). The rotor is mounted on a bearing-supported shaft, which can be connected to *mechanical loads* (if the machine is a motor) or to a *prime mover* (if the machine is a generator) by means of belts, pulleys, chains, or other mechanical couplings. The windings carry the electric currents that generate the magnetic fields and flow to the electrical loads, and also provide the closed loops in which voltages will be induced.

BASIC CLASSIFICATION OF ELECTRIC MACHINES

An immediate distinction can be made between different types of windings characterized by the nature of the current they carry. If the current serves the sole

purpose of providing a magnetic field and is independent of the load, it is called a *magnetizing*, or excitation, current, and the winding is termed a **field winding**. Field currents are nearly always direct current (DC) and are of relatively low power, since their only purpose is to magnetize the core (recall the important role of high-permeability cores in generating large magnetic fluxes from relatively small currents). On the other hand, if the winding carries only the load current, it is called an **armature**. In DC and alternating-current (AC) synchronous machines, separate windings exist to carry field and armature currents. In the induction motor, the magnetizing and load currents flow in the same winding, called the *input winding*, or *primary*; the output winding is then called the *secondary*. As we shall see, this terminology, which is reminiscent of transformers, is particularly appropriate for induction motors.

It is also useful to classify electric machines in terms of their energy conversion characteristics. A machine acts as a **generator** if it converts mechanical energy from a prime mover, say, an internal combustion engine, to electrical form. Examples of generators are the large machines used in power generating plants, or the common automotive alternator. A machine is classified as a **motor** if it converts electrical energy to mechanical form. The latter class of machines is probably of more direct interest to you, because of its widespread application in engineering practice. Electric motors are used to provide forces and torques to generate motion in countless industrial applications. Machine tools, robots, punches, presses, mills, and propulsion systems for electric vehicles are but a few examples of the application of electric machines in engineering.

Note that in Figure 14.1 we have explicitly shown the direction of two magnetic fields: that of the rotor \mathbf{B}_R and that of the stator \mathbf{B}_S . Although these fields are generated by different means in different machines (e.g., permanent magnets, alternating currents, direct currents), the presence of these fields is what causes a rotating machine to turn and enables the generation of electric power. In particular, we see that in Figure 14.1 the north pole of the rotor field will seek to align itself with the south pole of the stator field. It is this magnetic attraction force that permits the generation of torque in an electric motor; conversely, a generator exploits the laws of electromagnetic induction to convert a changing magnetic field to an electric current. To simplify the discussion in later sections, we now introduce some basic concepts that apply to all rotating electric machines. Referring to Figure 14.2, we note that for all machines the force on a wire is given by the expression

$$\mathbf{f} = iw\mathbf{l} \times \mathbf{B}$$

Where iw is the current in the wire, \mathbf{l} is a vector along the direction of the wire, and \times denotes the cross product of two vectors. Then the torque for a multi-turn coil becomes

$$T = KBiwsin \alpha$$

Where

B = magnetic flux density caused by stator field

K = constant depending on coil geometry

α = angle between \mathbf{B} and normal to plane of coil

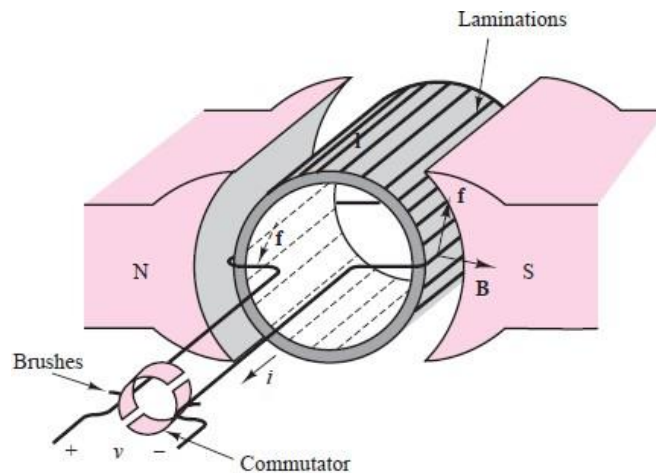

Figure 14.2 Stator and rotor fields and the force acting on a rotating machine

In the hypothetical machine of Figure 14.2, there are two magnetic fields: one generated within the stator, the other within the rotor windings. Either (but not both) of these fields could be generated by a current or by a permanent magnet. Thus, we could replace the permanent-magnet stator of Figure 14.2 with a suitably arranged winding to generate a stator field in the same direction. If the stator were made of a toroidal coil of radius R (see Chapter 13), then the magnetic field of the stator would generate a flux density B , where

$$B = \mu H = \mu \frac{Ni}{2\pi R}$$

and where N is the number of turns and i is the coil current. The direction of the torque is always the direction determined by the rotor and stator fields as they seek to align to each other (i.e., counterclockwise in the diagram of Figure 14.1). It is important to note that Figure 14.2 is merely a general indication of the major features and characteristics of rotating machines. A variety of configurations exist, depending on whether each of the fields is generated by a current in a coil or by a

permanent magnet and whether the load and magnetizing currents are direct or alternating.

DC MACHINE

FUNDAMENTAL:

Emf induced in coil $e = -N \frac{d\Phi}{dt}$ volt

Emf induced in a conductor $e = Blv$ volt

Force developed in a conductor $F = BIL N$

Electrical energy $E_n = VI t$ Whour

Electrical power (Active) $P=VI$ Watt

Resistance of conductor $R=\rho l/a$ Ohm

Eqn. of current by Ohm's law, $I=V/R$ A

Magnetizing force, $H=NI/L$ AT/m

Flux density, $B=\Phi/A$

Electrical field intensity, $E=V/d$ V/m

Current density, $J=I/a$ A/m²

INTRODUCTION :

DC machine is a device which converts mechanical energy into electrical energy and vice versa.

When the device acts as a generator (or dynamo), mechanical energy is converted into electrical energy.

On the other hand, when the device acts as a motor, electrical energy is converted into mechanical energy.

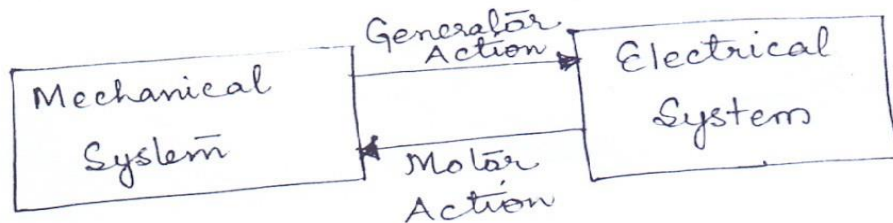

ESSENTIAL FEATURES:

There is no real difference between a dc. motor and dc generator either from the point of view of the essential components or of the fundamental principles involved.

In the generator there is a conversion of mechanical to electrical energy while in the motor there is the reverse conversion of electrical to mechanical energy. The structure difference is merely one of the enclosure. Most generators work in sheltered situations e.g. in power stations and an open type of construction is thus possible, the advantage being that all the parts are in consequence, easily accessible. Motors often work in exposed

Situations, where there are dirt as damp, chemical fumes, explosive gases and so on, and it may therefore be necessary to enclose all the working parts.

CONSTRUCTION:

<u>STATOR</u>	<u>ROTOR</u>
Yoke/Frame	Armature core
Field magnet (pole core & pole shoe)	Armature winding/ conductor
Main field winding	Commutator & Brushes
Interpoles/commutating poles	Shaft
Interpoles winding	Bearings

STATOR & ROTOR

All conventional electrical machines consist of a stationary member called the stator separated by an air gap from a rotating member called rotor.

In d.c machines the stator usually consists of salient poles with coils wound round them so as to produce a magnetic field.

The rotor is familiarly called the armature and consists of a series of coils located in slots around its periphery and connected to a commutator.

Yoke/Frame

Yoke is the outer frame dc m/c. It carries the magnetic flux provided by the pole and acts as a protecting shield for the entire machine. In small generators yokes are made of cast iron whereas in large machine cast sheet is used.

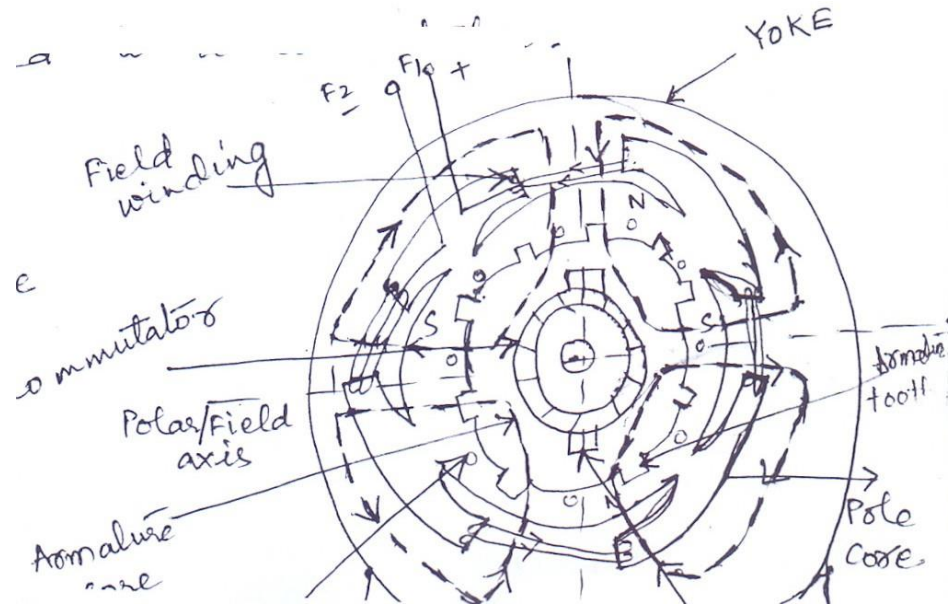

Field magnet :

It is a strong permanent magnet (in case of a small dynamo) or an electromagnet (in case of large dynamo) of intense magnetic field.

Pole core & Pole shoe : The field magnet has two parts

Pole core (pole pieces)

Pole shoes.

Pole core is made of cast steel or cast iron with laminated pole shoes screwed on to the holes in the yoke.

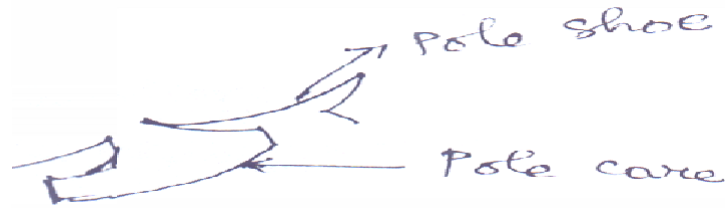

Pole shoes spread out the flux in the air gap and reduce the reluctance of the magnetic path due to its large cross -section.

Poles shoes support the exciting coils.

Pole coils (field winding)

- It is otherwise known as exciting winding
- These are fine copper wire (or strip) wound around the pole pieces
- The flux produced by the winding is cut by the revolving armature

ARMATURE CORE:

- It houses armature coils in the slots. It is cylindrical or drum shaped.
- Armature is placed in between the two poles of field magnet and is rotated about its central axis mechanically (by a prime mover)

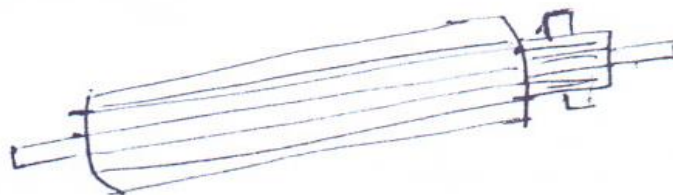

- It is usually made of circular sheet steel disc or laminations.

- Thickness of laminations is of the order of 0.5mm. Perforations exist in these laminations to provide axial flow of air through the armature for cooling purposes.
- Armature core is keyed to the shaft.
- During rotation it cuts the magnetic flux of the field magnets.
- It also provides a path of very low reluctance to the flux from north pole to south pole.

ARMATURE WINDING:

- It is made up of copper.
- It consists of large no. of insulated coils, each coil having one or more turns.
- Armature conductor are placed in armature slots.

Commutator:

- It converts the alternating current produced in the armature conductors into direct current.
- It consists of wedge shaped copper segments (Insulated from either side to form a ring. The number of segments of commutator equals the no. of armature coils.
- It facilitates the collection of current from the armature conductors.

Brushes

- They are fixed on the commutator by pressure springs.
- They are usually made of a high grade carbon or graphite and are in the shape of rectangular block.

- These are housed in a brush holder.
- They collect the current from the commutator and finally they pass on the EMF generated to load.

Bearing

- The armature shaft is supported at the commutator end on ball or roller bearings which are packed in hard oil.
- They provide quieter operation, together with reduced wear and tear.
- Ball bearings are frequently employed for their reliability.
- Roller bearings are preferable for heavy duties.

Interpoles

- In addition to the main poles, the dc machines are usually fitted with auxiliary poles placed between the main poles and they are called interpoles, the purpose of which is to provide better commutation.
- It minimizes sparking at the commutator.

Types of Armature Winding

These are of two types : Lap winding

Wave winding

Pole Pitch

- It is defined as the no of armature conductors per pole.
- If there are 80 conductors and 8 poles, pole pitch is $80/8 = 10$.

Conductor

- It is defined as the length of a wire lying the magnetic field as shown in fig1.

Coil

- Two conductors with their end connections shown in fig1 from one coil.

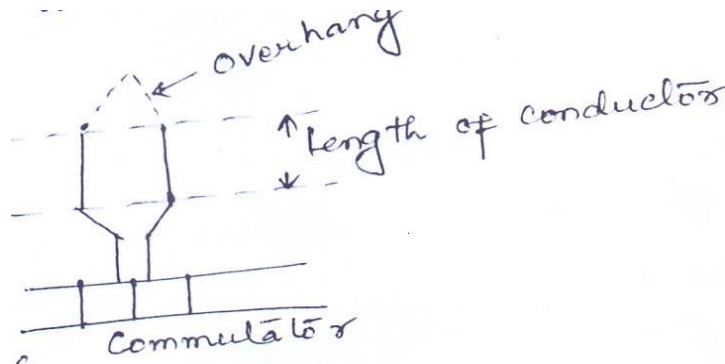

- Coil may be single turn coil or multi-turn coil.
- End connections are called overhang.

Coil Pitch

- It is defined as the distance between two sides of a coil in terms of armature slots.
- It is defined as the periphery of the armature between two sides of a coil.
- If the coil pitch is equal to the pole pitch, the winding is said to be full pitched, otherwise it is half-pitch

Pitch:

It is defined as the distance between the second conductor one coil and the first conductor of the next coil as shown in fig.2 & 3.

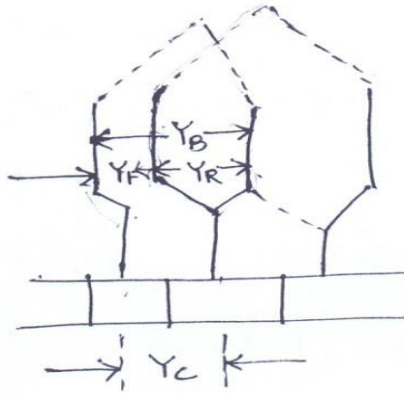

Fig 2. Lap wdng

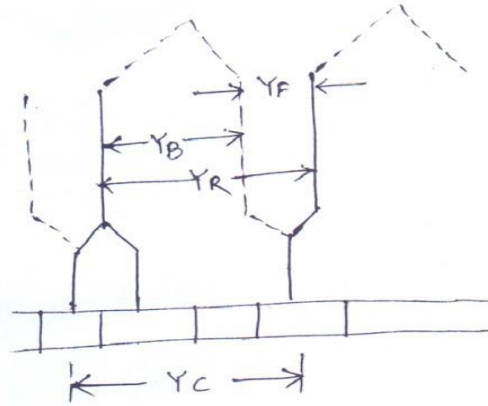

Fig 3. wave winding

Back Pitch :

It is defined as the distance measured in terms of armature conductors that a coil advances on the back side of the armature as shown in fig.2 & 3.

Resultant Pitch: (Y_R)

It is defined as the distance between the beginning of one coil and the beginning of the next coil or

lap winding $Y_R = Y_B - Y_F$

wave winding $Y_R = Y_B + Y_F$

Coil Pitch (Y_c):

It is defined as the distance between the beginning of one coil to the beginning of the next coil as shown in fig 2 & 3 for lap and wave winding respectively.

Lap winding:

To get these type of the following rules are commonly used: winding must be full pitched i.e.

$$Y_B + Y_F = \text{Pole Pitch}$$

1. To place the coil properly on the armatures, the front pitch as well as back pitch must be odd.
2. No. of commutator segment = no. of coils.
3. winding must close upon itself.
4. $Y_c = \pm 1$

For Progressive or right handed winding

$$Y_F = Z/P - 1 \quad \text{and} \quad Y_B = Z/P + 1$$

For Retrogressive or left handed winding

$$Y_F = Z/P + 1 \quad \text{and} \quad Y_B = Z/P - 1$$

Wave Winding:

1. Y_B & Y_F are odd and of opposite sign.
2. Y_B & Y_F are nearly equal to the pole pitch and differ by 2.
3. $Y_C = (\text{No. of commutator bars} \pm 1) / \text{No. of pairs of pole}$

Comparison:

Lap winding	Wave winding
No. of parallel paths = no. of poles	No of parallel path = 2
No. of brushes sets = no. of poles	No. of brushes sets = 2
Used for high current & low voltage	Used for low current & high voltage

PRINCIPLE OF OPERATION OF DC GENERATOR:

Principle:

Faradays law of electromagnetic induction according to which emf is induced in the conductors which drives the current through the conductor.

Fig below shows a single turn generator.

The coil is rotated in anticlockwise direction with the help of prime mover.

Fig. shows the different instants of the induced emf due to different positions of the coil.

Magnetic field is produced either by a permanent magnet or an electromagnet energised by the DC supply.

When the angle $\theta = 0^\circ$, the coils is perpendicular to the magnetic field and the instantaneous component of velocity of conductors ab and cd is parallel to the magnetic field .

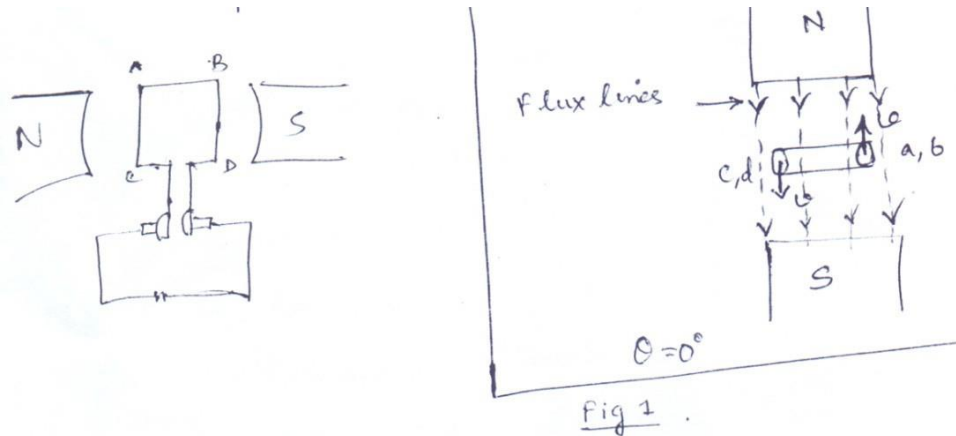

The flux linked with the coil is maximum but the rate of change of flux is minimum. Hence emf cannot be generated . Therefore current flows through the conductors.

When $0 < \theta < 90^\circ$, due to the rotation of the coil in the anticlockwise direction, the velocity of the conductor has two components that is $v \sin \theta$ and $v \cos \theta$. Therefore the conductors will cut the flux due to $v \sin \theta$. Hence emf is induced in the conductors and current flows in the conductors.

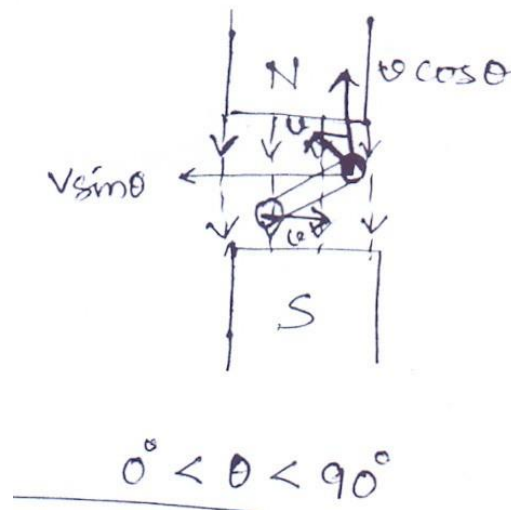

If when $\theta = 90^\circ$, coil is parallel to the magnetic field and the instantaneous component of velocity of conductors ab and cd is perpendicular to the magnetic field. The flux linked with the coil is minimum but the rate of change of flux is maximum. Hence emf generated is maximum. Therefore maximum current flows through the conductors.

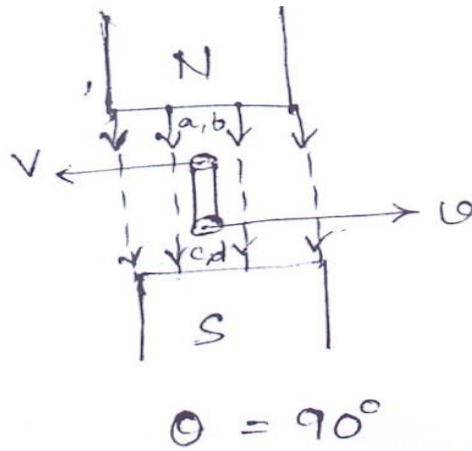

When the coil rotates from $\theta = 90^\circ$ to $\theta = 180^\circ$, the components of velocity that is $\sin \theta$ of conductors perpendicular to the field decreases and hence emf is induced in the conductor and current flow in the conductors.

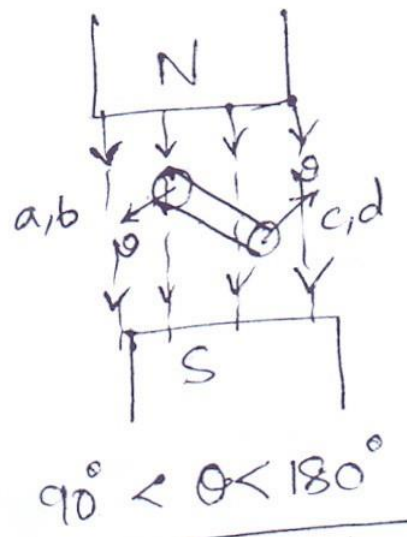

When $\theta = 180^\circ$, the coil is perpendicular to the magnetic field and the instantaneous components of velocity of conductors ab and cd is parallel to the magnetic field.

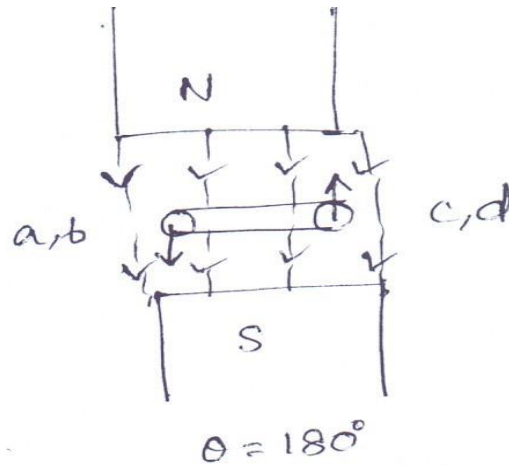

The flux linked with the coil is maximum but the rate of change of flux is minimum. Hence emf cannot be generated. Therefore the current flows through the conductor.

When $180^\circ < \theta < 270^\circ$ due to rotation of the coil in the anticlockwise direction, the velocity of the conductors has two components that is $v \sin \theta$ and $v \cos \theta$ and the direction is opposite to the case when $0^\circ < \theta < 90^\circ$. Therefore the conductor have the flux due to $v \sin \theta$.

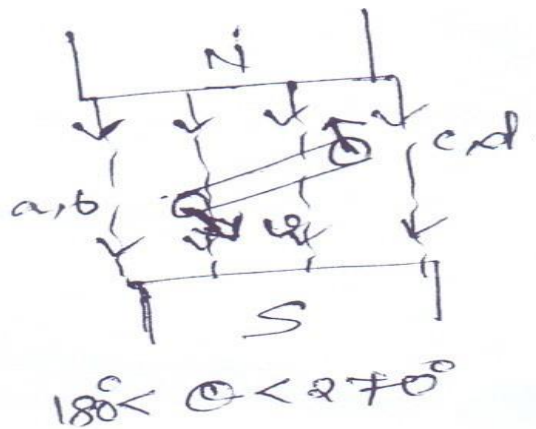

Hence emf is induced in the conductors in the direction opposite to the cases of $0^\circ < \theta < 90^\circ$ and current flows in the conductors in the direction opposite to the $0^\circ < \theta < 90^\circ$. Similarly the other case till $\theta = 360^\circ$.

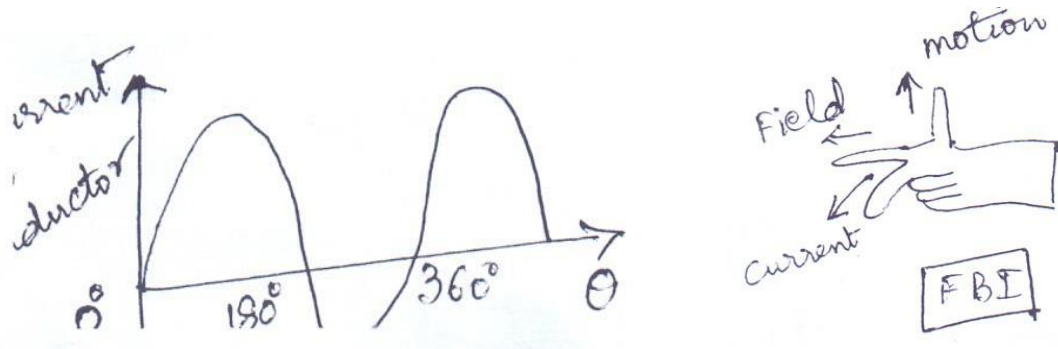

The direction of flow of current through the conductor can be found by Fleming's right hand rule. To have a unidirectional current commutator is used.

Fig below shows a split ring where two segments A and B are separated by an insulating material. Let the conductor 1 be connected to segment A and conductor 2 be connected to segment B.

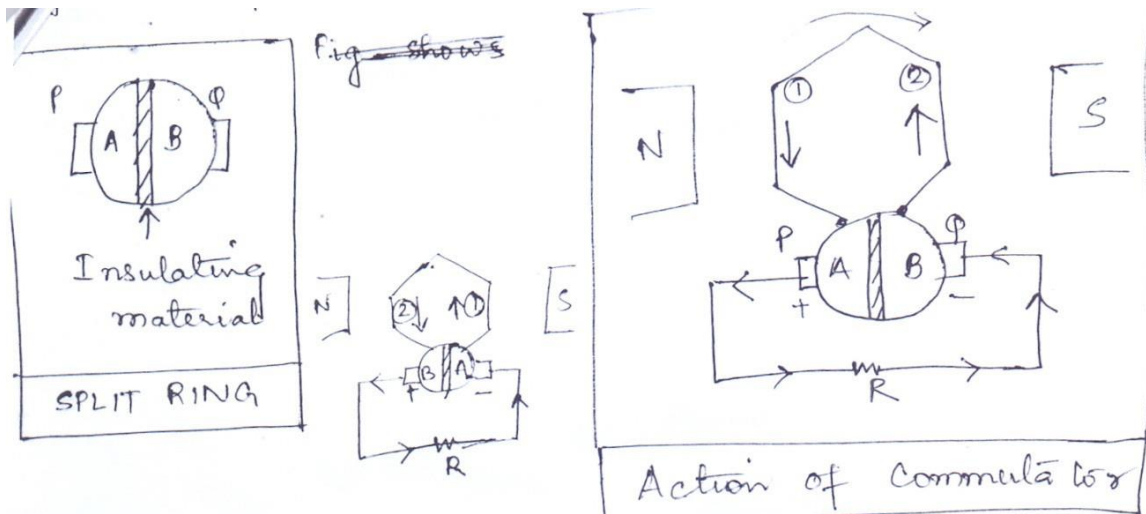

The conductor 1 carries current in the downward direction while the conductor 2 carries current in the upward direction and current through the resistance R flows

from P to Q. After one half of rotation, conductor 1 and 2 come under the influence of south and north pole respectively.

The split ring is mounted on the shaft and it rotates with the armature. The split ring will reverse this positions with the reversing of the position of the conductors, but the direction of current flow through the conductor remains unaltered because the P & Q are stationary.

Equivalent circuit of a DC Machine

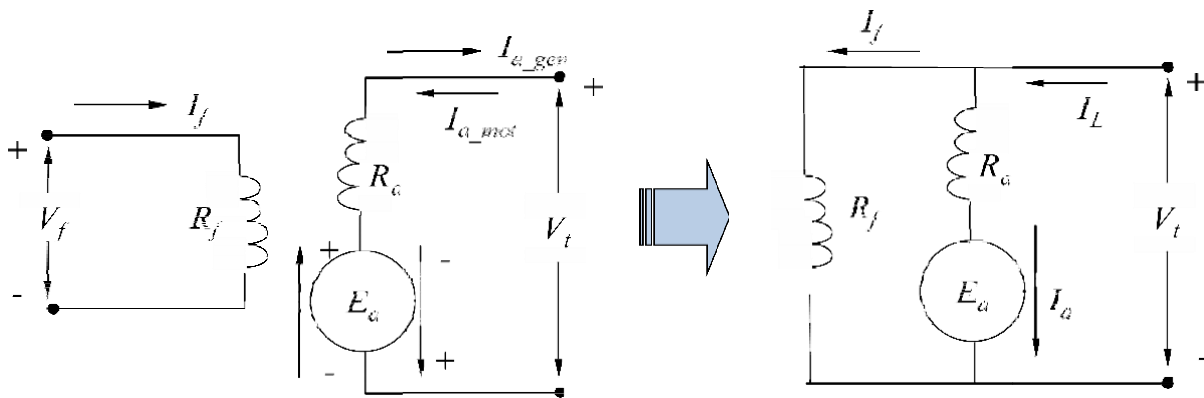

$$V_f = I_f R_f$$

$$V_t = E_a \pm I_a R_a$$

Generated EMF and Electromagnetic Torque

$$V_f = I_f R_f$$

$$V_t = E_a \pm I_a R_a$$

Motor: $V_t > E_a$

Generator: $V_t < E_a$

Voltage generated in the armature circuit due the flux of the stator field current:

$$E_a = K_a \phi_d \omega_m$$

K_a : design constant

Electromagnetic torque:

$$T_e = K_a \phi_d I_a$$

$$P_{em} = E_a I_a = T_e \omega_m$$

Types of DC Machines

Both the armature and field circuits carry direct current in the case of a DC machine.

Self-excited DC machine: when a machine supplies its own excitation of the field windings. In this machine, residual magnetism must be present in the ferromagnetic circuit of the machine in order to start the self-excitation process.

Separately-excited DC machine: The field windings may be separately excited from an external DC source.

Shunt Machine: armature and field circuits are connected in parallel. Shunt generator can be separately-excited or self-excited.

Series Machine: armature and field circuits are connected in series.

Separately-Excited and Self-Excited DC Generators

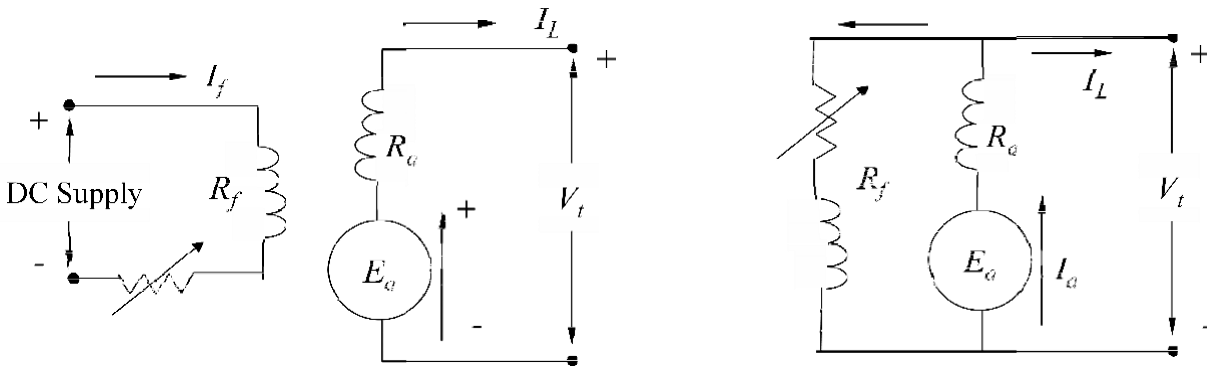

Example: A 100-kW, 250-V DC shunt generator has an armature resistance of 0.05 Ω and field circuit resistance of 60 Ω . With the generator operating at rated voltage, determine the induced voltage at (a) full load, and (b) half-full load.

Ans. (a) At full load,

$$V_t = E_a - I_a R_a$$

$$I_f = 250/60 = 4.17 \text{ A}$$

$$I_{L_FL} = 100,000/250 = 400 \text{ A}$$

$$I_a = I_{L_FL} + I_f = 400 + 4.17 = 404.17 \text{ A}$$

$$E_a = V_t + I_a R_a = 250 + 404.17 * 0.05 = 270.2 \text{ V}$$

(b) At half load,

$$I_f = 250/60 = 4.17 \text{ A}$$

$$I_{L_HL} = 50,000/250 = 200 \text{ A}$$

$$I_a = I_{L_HL} + I_f = 200 + 4.17 = 204.17 \text{ A}$$

$$E_a = V_t + I_a R_a = 250 + 204.17 * 0.05 = 260.2 \text{ V}$$

AC MACHINES

AC machines have large advantages over DC machines. They are,

- Since basic generation of electricity is in the form of AC voltage, no converting device is necessary.
- Suitable for large ratings (upto more than 500 MW)
- Cost of an AC machine for same power and voltage rating is less than that of DC machines
- Since transformers are used in AC only, AC generation is must for commercial purpose operation.

AC machines are broadly classified as:-

- Synchronous machine
 - Operates at constant speed and constant frequencies under steady state condition
 - Generator known as alternator
 - Faradays laws of electromagnetic induction
 - Does not have commutator
 - EMF is generated from mutual interaction between conductors and magnetic flux.
- Asynchronous machine
 - Operates with variable speed
 - Induction machine
 - Induction motor application in air conditioning, industrial use (rolling mills)
 - Induction generator application in wind generating system :- convert wind energy to electrical energy at constant frequency irrespective of wind speed

Three phase Induction Motor:

- Three-phase induction motors are the most common and frequently encountered machines in industry
 - simple design, rugged, low-price, easy maintenance
 - wide range of power ratings: fractional horsepower to 10 MW
 - run essentially as constant speed from no-load to full load
 - Its speed depends on the frequency of the power source
- Construction:-
 - **Stator** :- three phase winding in star or delta
 - **Rotor** :-
 - ✓ **Squirrel cage rotor**
 - rotor windings are shorted internally
 - ✓ **Slip ring or phase wound rotor**
 - rotor windings are short circuited externally through three slip rings
 - Rotor windings are short circuited
 - Slip (S) :- difference between the speed of rotor (N) and the speed of rotating magnetic field (Ns). It is expressed in % as:
$$S = \left[\frac{N_s - N}{N_s} \right] \times 100$$
 - Slip varies from syn. Speed (Ns) to 1 (When the rotor is at rest)

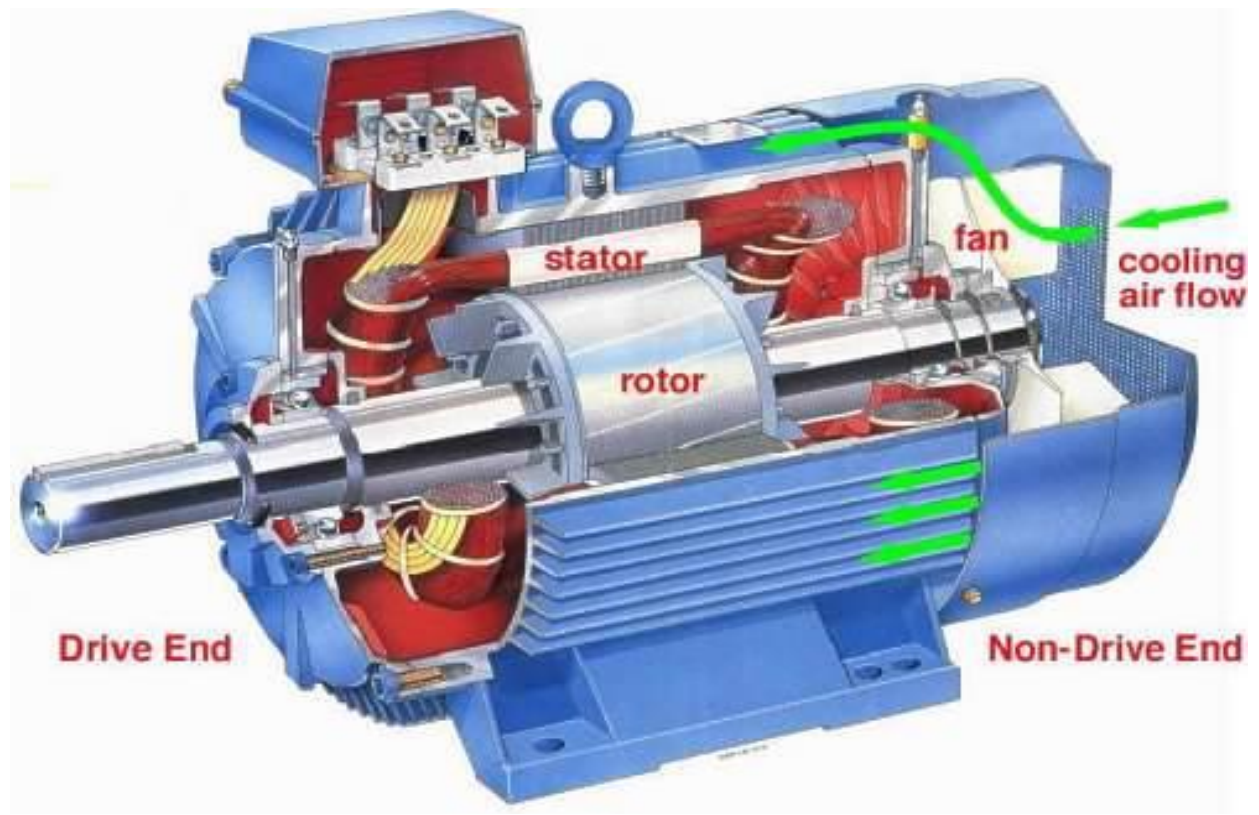
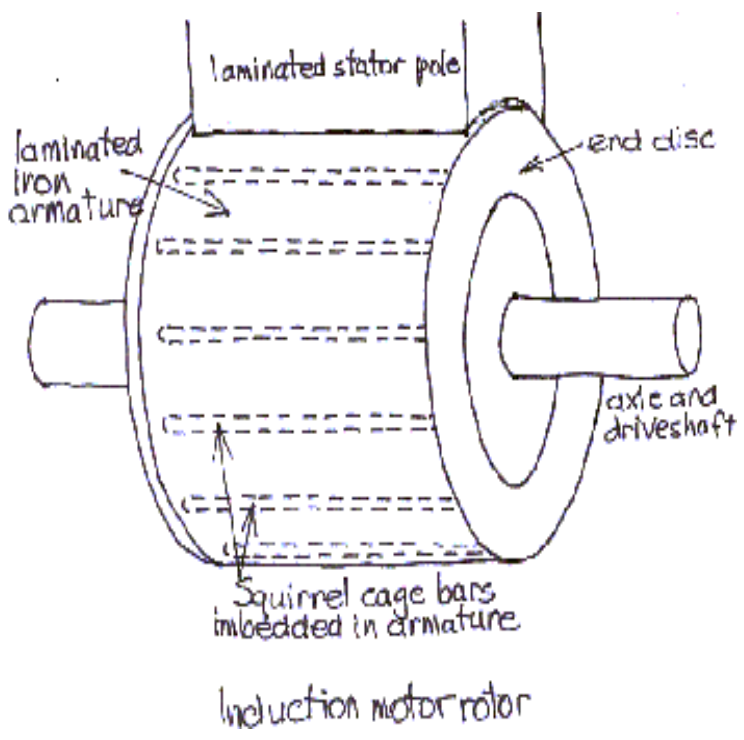
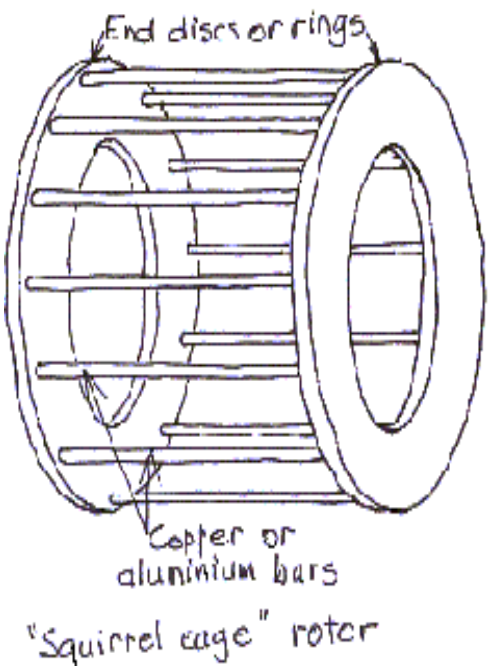

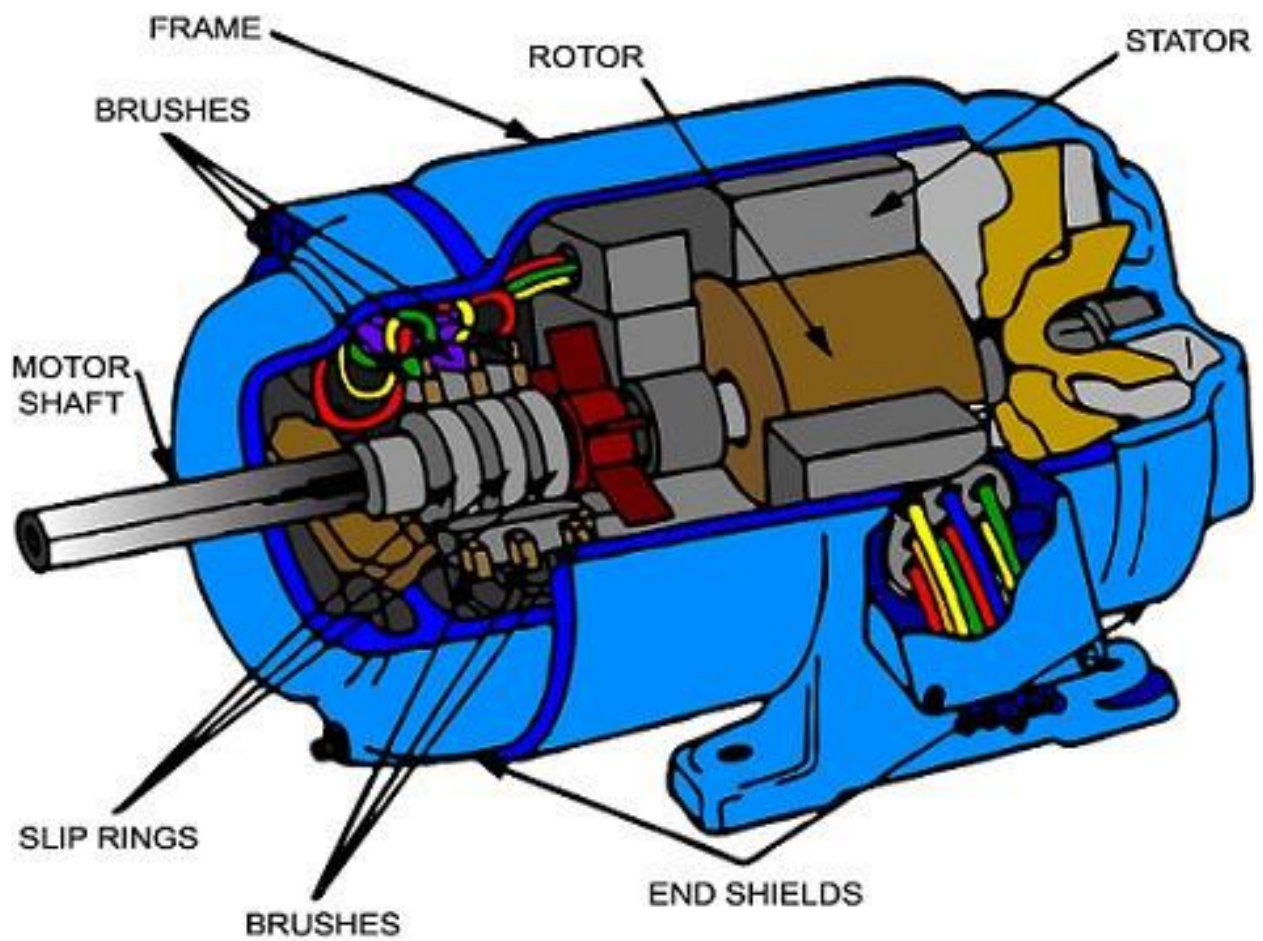
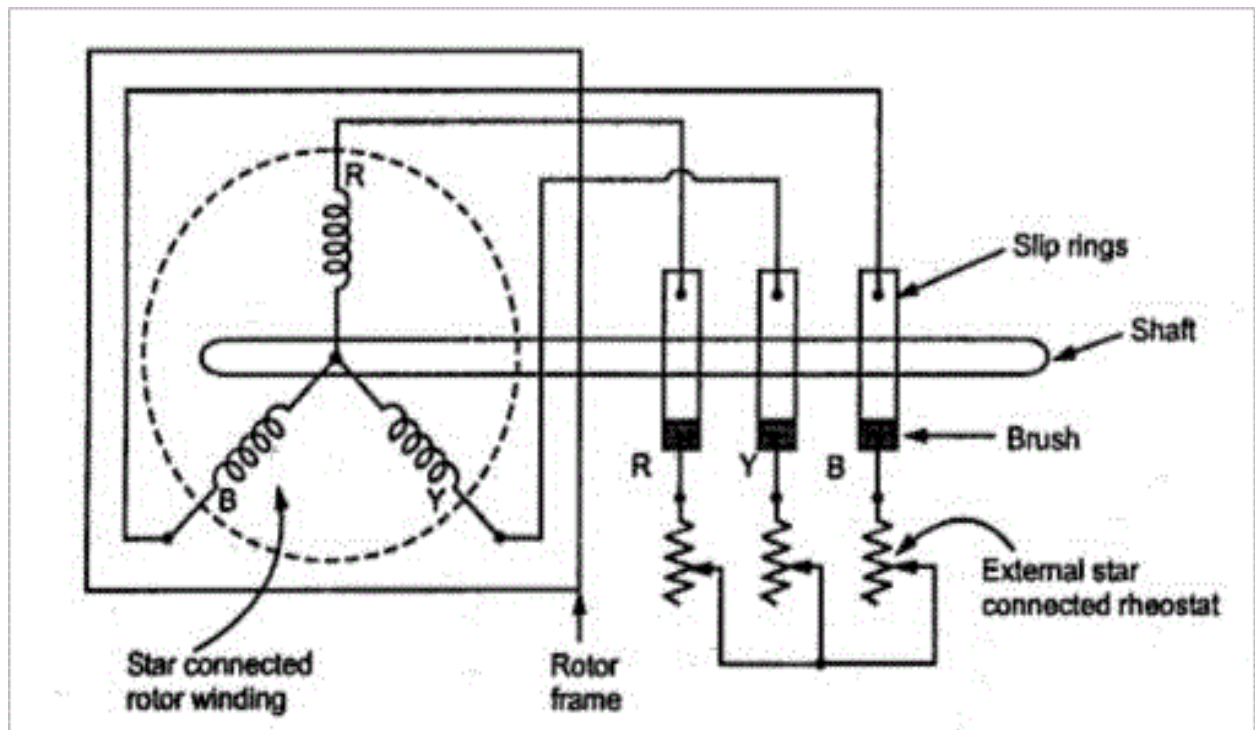

Rotating Magnetic Field

- Balanced three phase windings, i.e. mechanically displaced 120 degrees from each other, fed by balanced three phase source
- A rotating magnetic field with constant magnitude is produced, rotating with a speed

$$n_{sync} = \frac{120 f_e}{P} \text{ rpm}$$

Where f_e is the supply frequency and

P is the no. of poles and n_{sync} is called the synchronous speed in *rpm* (revolutions per minute)

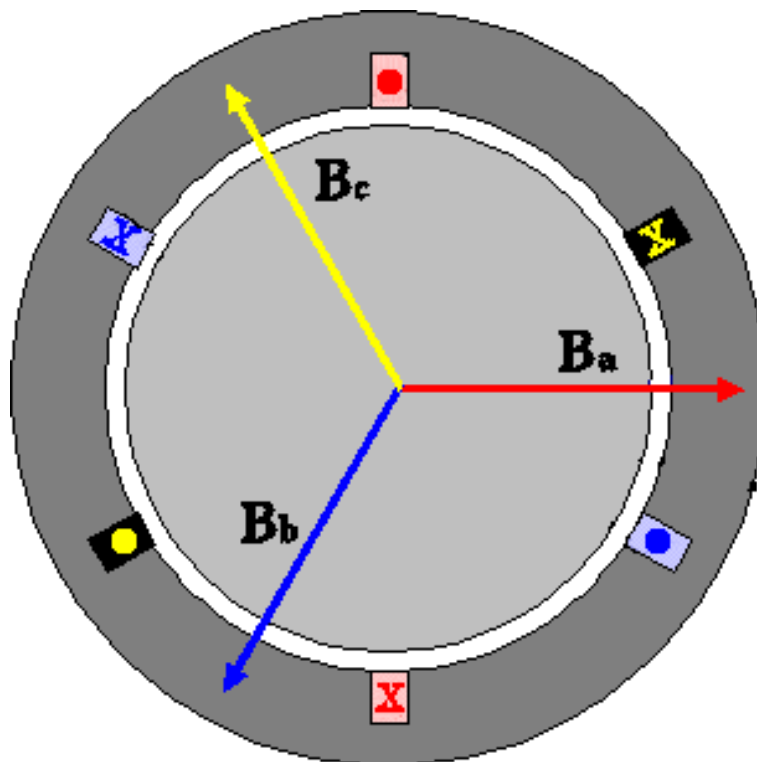

Principle of operation:

- This rotating magnetic field cuts the rotor windings and produces an induced voltage in the rotor windings
- Due to the fact that the rotor windings are short circuited, for both squirrel cage and wound-rotor, and induced current flows in the rotor windings
- The rotor current produces another magnetic field

A torque is produced as a result of the interaction of those two magnetic fields

$$\tau_{ind} = k B_R \times B_s$$

Where τ_{ind} is the induced torque and B_R and B_s are the magnetic flux densities of the rotor and the stator respectively

Slip: The difference between synchronous speed N_s and actual speed N of the rotor is known as slip.

$$\% \text{ Slip} = \frac{N_s - N}{N_s} \times 100 \%$$

Sometimes, $N_s - N$ is called slip speed

Frequency of rotor (f'):

$$N_s - N = \frac{120 f'}{P}$$

$$N_s = \frac{120 f}{P}$$

$$\frac{N_s - N}{N_s} = \frac{f'}{f}$$

$$f' = s f$$

Torque Equation:

$$T_{EM} = \frac{60}{2\pi N_s} * \text{rotor .input}$$

Unit- synchronous watt

TORQUE- SLIP OR TORQUE-SPEED CHARACTERISTICS

$$T_{EM} = \frac{180}{2\pi N} * \frac{SE_2^2 R_2}{R_2 + (SX_2)^2}$$

For a constant supply voltage, E_2 is also constant. So we can write torque equation as:-

$$T \propto \frac{SR_2}{R_2^2 + (SX_2)^2}$$

As R_2 is constant.

1) HIGH SLIP REGION –

Here S is high

So,

$$T \propto \frac{SR_2}{(SX_2)^2} \propto \frac{1}{S}$$

As R_2 and X_2 are constants

$$T_{Full\ Load} < T_M$$

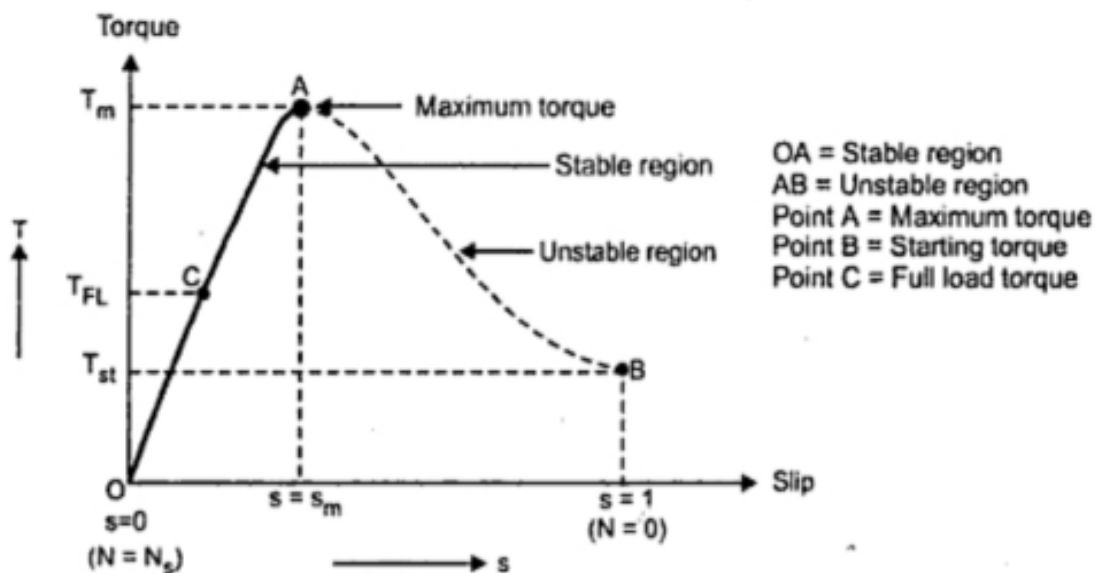

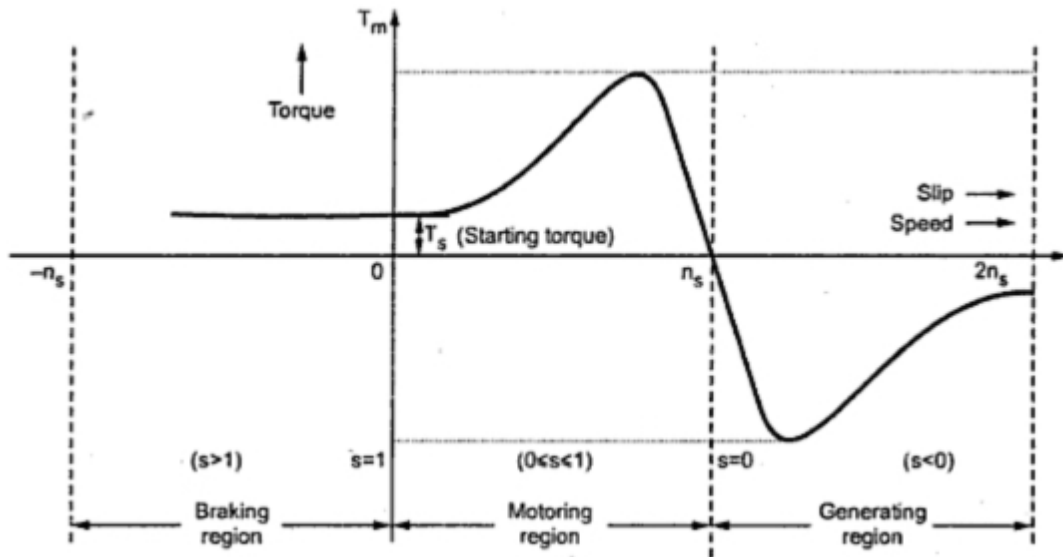

EQUIVALENT CIRCUIT

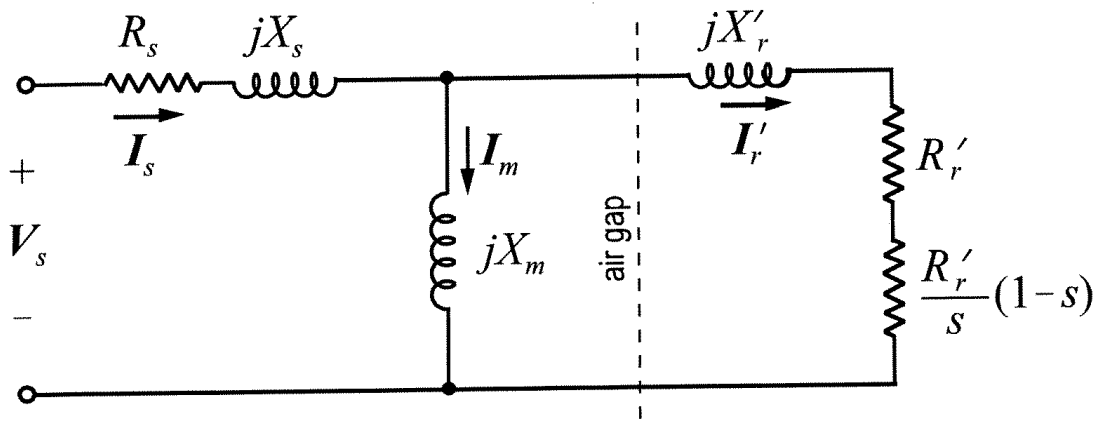

Introduction to 1-phase induction motor:

- Used for domestic application
- 1-phase IM are fractional KW motors
 - Rotor – squirrel cage
 - Stator – distributed

Types of 1-phase IM:

- Resistance split phase IM
- Capacitor split phase IM
 - Capacitor start IM

- Capacitor start capacitor run IM
- Capacitor run IM

Synchronous Machine Construction:

- Field :- carrying a DC excited winding
- Armature : three phase winding in which emf is generated
- Armature stationary and rotating field structure
- Armature winding is built of sheet-steel laminations having slots on its inner periphery
- Three phase winding is placed in these slots and serves as armature winding.
- connected in star
- Field is connected to an external source through slip rings and brushes or else receives excitation from rotating bodies
- Damper bars on the rotor :- damps the oscillations due to transients
- Depending on rotor construction:-
 - Round rotor type
 - High speed machine such as turbine generators
 - Salient pole type

Low speed such as water wheel generator

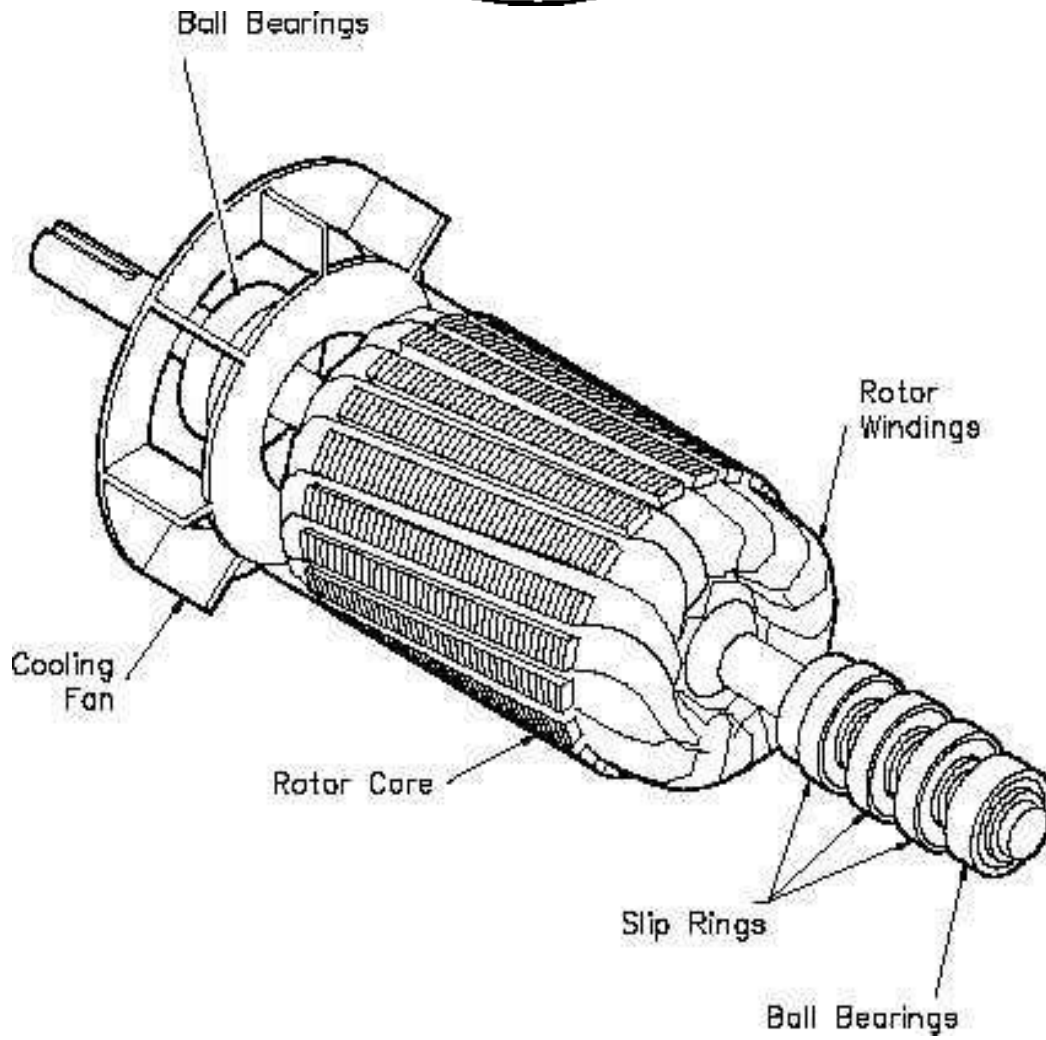
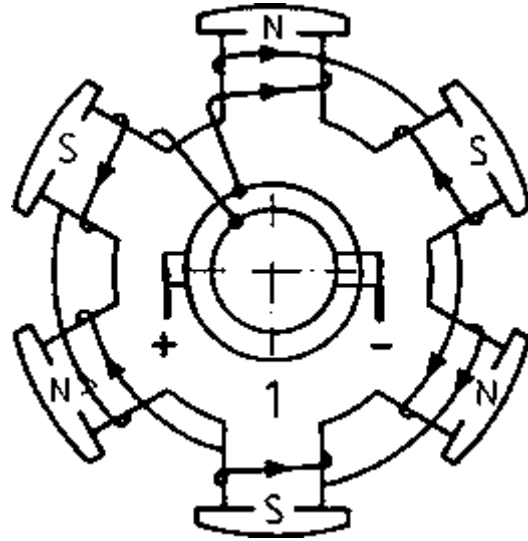

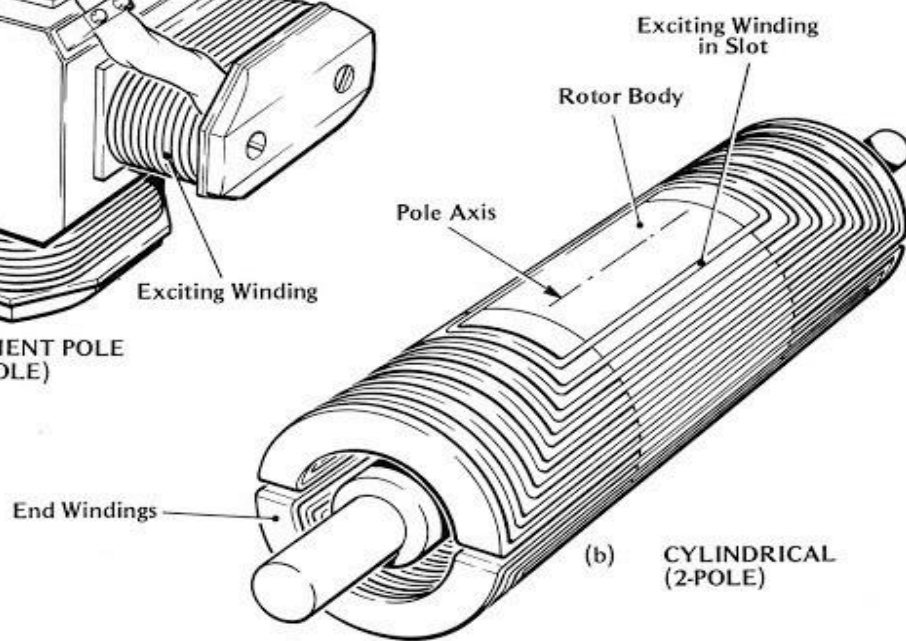
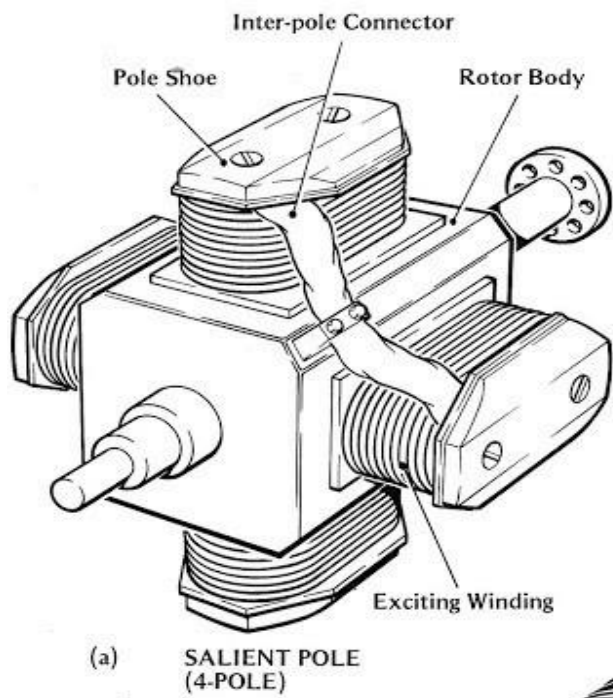

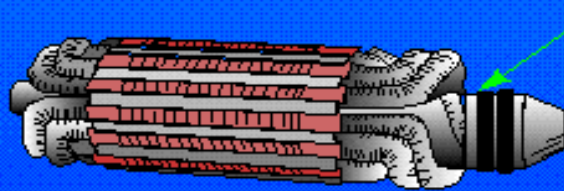
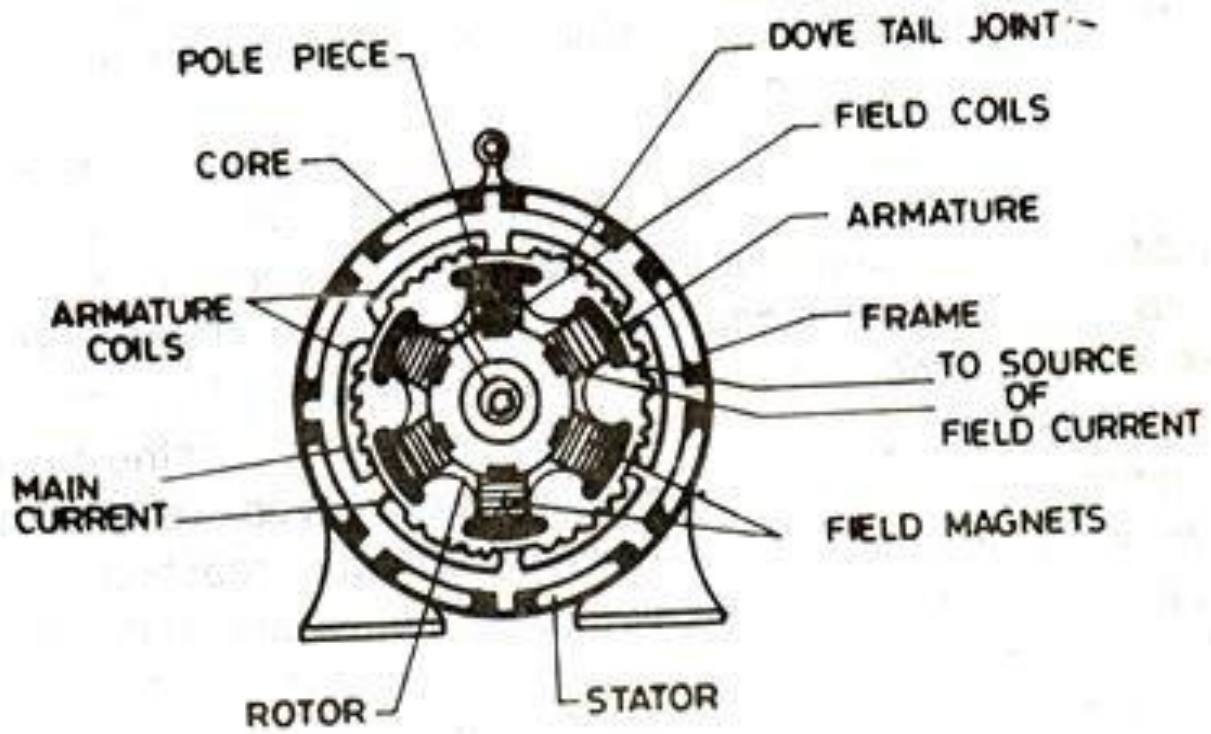

TURBINE DRIVEN ROTOR

HIGH SPEED = 1200 RPM OR MORE

SLIP RINGS

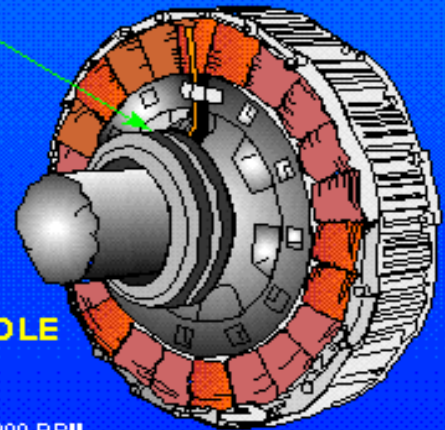

SALIENT-POLE ROTOR

LOW SPEED = 1200 RPM OR LESS

CROSS - SECTION



A

SCHEMATIC

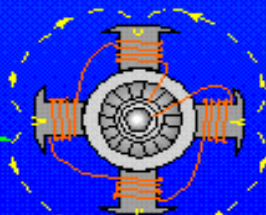

B

LINES OF MAGNETIC FORCE

Frequency of output voltage:

Let P = no of rotor poles

N= Speed of the rotor in rpm

Number of cycles generated in one revolution = P/2

Time taken for one revolution = 60/N seconds

In 60/ N sec, no. of cycles = P/2

In 1 sec, no. of cycles generated = P/2/60/N = PN/120

So, frequency (f) = PN/120 Hz

Emf equation:

Let P = no of poles

N= speed in rpm

T_{ph} = no of concentric turns

K_d = distribution factor

Φ = flux produced per pole in weber

In one revolution flux cut by one armature conductor = $\Phi P = d\Phi$

Time taken for one revolution = 60/N sec = dt

Therefore average emf induced in the conductor is given by

$$e = d\Phi/dt = \Phi P/60/N = \Phi P N/60 = 2\Phi P N/120$$

$$e = 2\Phi f \text{ volts}$$

$$\text{therefore, } f = PN/120$$

For a sinusoidal ac voltage,

rms value = average value x form factor

The value of form factor is 1.11 in case of sinusoidal a.c

Rms value of induced emf per conductor = 1.11 x e

$$= (1.11) \times (2\Phi f)$$

$$= 2.22 \Phi f \text{ volts}$$

Emf per turn = $2 \times 2.22\Phi f = 4.44\Phi f$ volts (Two conductors constitute one turn)

Therefore, Induced emf per phase = emf per turn \times no of turns per phase = $4.44 \Phi f T_{ph}$ volts

In practice, the stator winding is distributed. So, the actual induced emf will be slightly less than the calculated value and the induced emf per phase is multiplied by a factor K_d , known as distribution factor. (Generally K_d varies from 0.96 to 0.98).

Synchronous Motor

Salient features:

- It is not self starting
- It rotates at constant speed irrespective of the load torque
- Speed at which it rotates is synchronous speed ($N_s = NP/120$ rpm)
- Draws current from the supply at any power factor (lagging, leading and unity)
- Needs both 3- ϕ AC supply (stator) and DC supply (rotor)
- Costlier

Starting of synchronous Motor:

A synchronous motor is not self starting. It can be started by the following two methods:

1. Starting with the help of an external prime mover
2. Starting with the help of damper windings

Motor starting with external prime mover:

In this method an external motor drives the synchronous motor and brings it to synchronous speed. The synchronous machine is then synchronized with the bus-bar as a synchronous generator. The prime mover is then disconnected. Once in parallel, the synchronous machine will work as a motor. Now the load can be connected to the synchronous motor. Since load is not connected to the synchronous motor before synchronizing, the starting motor has to overcome the inertia of the synchronous motor at no load. Therefore the rating of the starting

motor is much smaller than the rating of the synchronous motor. At present most large synchronous motors are provided with brushless excitation systems mounted on their shafts. These exciters are used as starting motors.

Motor starting with damper winding:

It is the most widely used method. A damper winding consists of heavy copper bars inserted in slots of the pole faces of the rotor. These bars are short-circuited by end rings at both ends of the rotor. Thus, these short-circuited bars form a squirrel cage winding. When a three phase supply is connected to the stator, the synchronous motor with damper winding will start as a three-phase induction motor. As the motor approaches synchronous speed, the dc excitation is applied to the field windings. The rotor will then pull into step with the stator magnetic field.

Hunting: The phenomenon of oscillation of the rotor about its final equilibrium position is called hunting. The term hunting is used to signify that after sudden application of load, the rotor attempts to search for or hunt for its new equilibrium space position. Hunting occurs not only in synchronous motors but also in the synchronous generators upon the abrupt change in loading. Hunting leads to loss of synchronism, variation of supply voltage producing undesirable lamp flicker, increases the possibility of resonance, develops mechanical stress in the rotor shaft, and increases the losses and the temperature of the machine. Hunting can be reduced by using damper winding, using flywheel, by designing with suitable synchronizing power coefficients.

Application of synchronous motor:

- In constant speed application
- Used as high power and high speed compressors, blowers, induced and forced draft fans, mainline traction, servo drives etc
- Used in power transmission systems to regulate line voltage
- Used to improve overall power factor of the plant

Solved Question:

Q1. A dc shunt generator generates an emf of 520 V at a speed of 1200 rpm. It has 2000 armature conductors and flux per pole is 0.013 wb. The armature winding has 4 parallel paths. i) Determine the number of poles ii) Find the generated voltage, if the armature winding is wave connected
(1st Semester 2004)

Solution. Given: $E = 520$ V, $N = 1200$ rpm, $Z = 2000$, $\Phi = 0.013$ wb, $A = 4$

i) $E = P\Phi ZN/60A$

$$\Rightarrow P = 60 AE/\Phi ZN = 60 \times 4 \times 520/0.013 \times 2000 \times 1200 = 4$$

ii) $E = P\Phi ZN/60A = 4 \times 0.013 \times 2000 \times 1200 / 60 \times 2 = 1040$ volts

Q2. A DC shunt motor develops 200 V on no load, while running at 1200 rpm. If the machine has 4 poles and 100 lap wound armature conductors, calculate the flux per pole. Also calculate the shunt field current if the resistance of the shunt field is 200 ohms.
(1st Semester 2009)

Solution: Given: $E_b = 200$ volts, $N = 1200$ rpm, $P = 4$, $Z = 100$, $A = P = 4$, $R_{sh} = 200 \Omega$

Therefore, Flux per pole (Φ) = $60 A E_b/ZNP = 60 \times 4 \times 200/ 100 \times 1200 \times 4 = 0.1$ wb

Neglecting armature resistance supply voltage, $V = E_b = 200$ volts

Shunt field current $I_{sh} = V/ R_{sh} = 200/ 200 = 1$ A

Q3. A 3 phase, 50 Hz induction motor has 8 poles. If the full load slip is 2.5%, determine i) synchronous speed ii) Rotor speed iii) Frequency of the rotor current

(Supplementary Exam 2004)

Solution: Given: $f = 50$ Hz, Pole (P) = 8, Full load slip = 0.025

i) Synchronous speed, $N_s = 120 f/P = 120 \times 50/8 = 750$ rpm

ii) Rotor speed, $N = N_s(1-S) = 750(1-0.025) = 731.25$ rpm

iii) Frequency of the rotor current $f' = sf = 0.025 \times 50 = 1.25$ Hz